

DCO		REV		REVISIONS	DESCRIPTION	DATE

Bracket, Swing Arm
05-18-108

Swing Arm
05-18-110

Pusher, Swing Arm
05-18-109

Drive, Swing Arm
05-18-111

M4x0.7 SHCS 10 mm Long

Dowel Pin Ø1/16 x 3/4" Long

M4x0.7 10mm Long SHCS
Head Turned to Ø.240"

M5x0.8 SHCS 21mm Long
Use to mount assy to Backplate
05-01-137

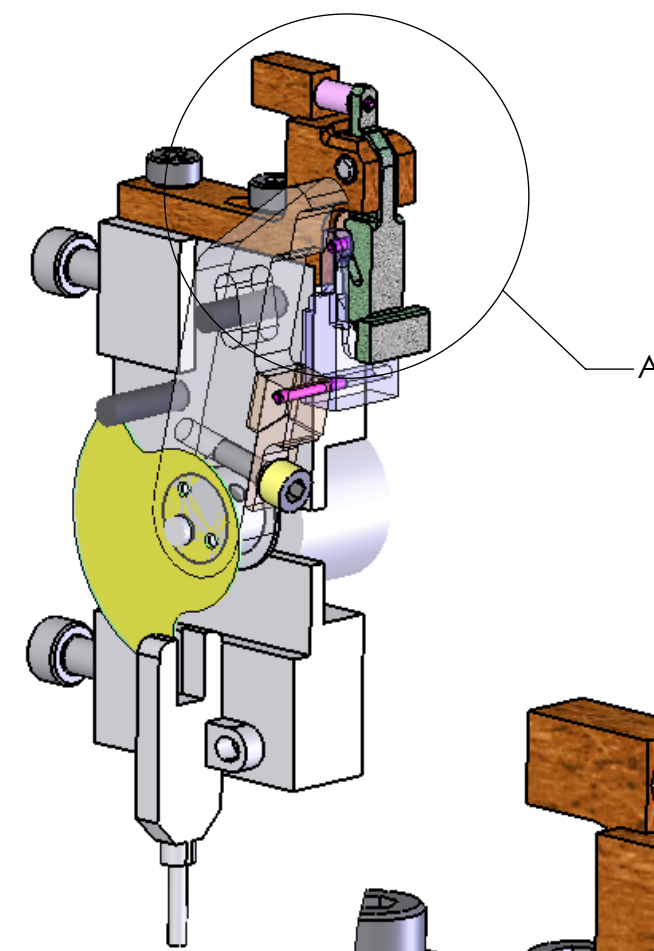

A

Spring
C0148-021-0750-M

Split Pin Ø1/16 x 1/4" Long

Dowel Pin Ø1/8 x 3/4" Long

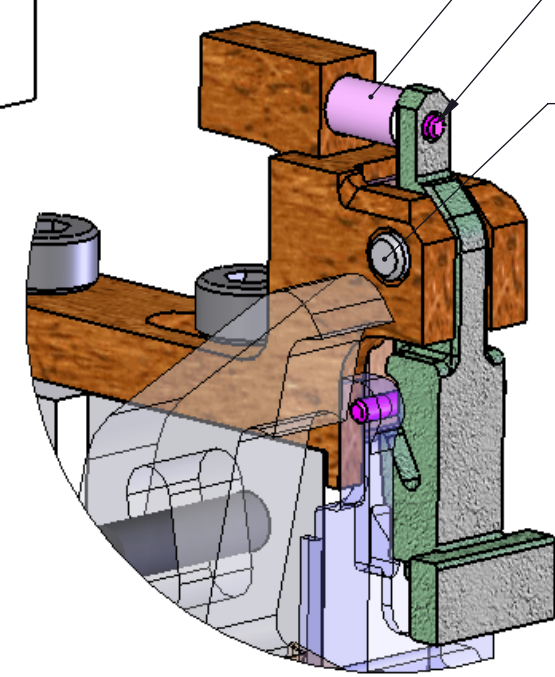

DETAIL A

DIMENSIONAL TOLERANCE U.O.S.

	INCH	METRIC
.X	±1/16"	±1.587mm
.XX	±.030"	±.762mm
.XXX	±.010"	±.254mm
.XXXX	±.005"	±.127mm

ANGLES ± .5°



DRAFTING			TITLE	
SIGNATURE	DATE		Assembly, Swing Arm	
MECH ENG	Mark Smith	10/31/06	SHEET SIZE B	ELECTRONIC FILE NAMES 05-18-107B.drw 05-18-107B.SLDASM
ELEC ENG				
MANUFACTURING			DRAWING NUMBER 05-18-107	
OPERATIONS			SCALE: 2:1	SHEET 1 of 1
			REVISION B	